

Assembly Instruction

Woodstock
1055729

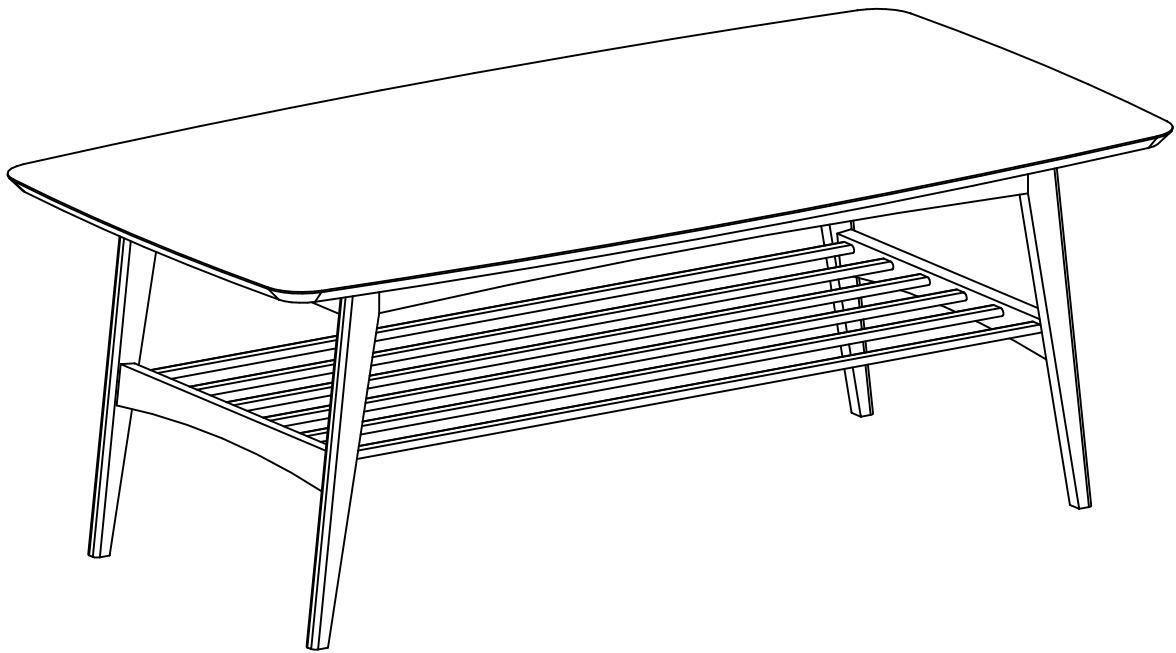

120 x 60 x 47 cm

BEMÆRK

Dit nye møbel er leveret med en grund olie overfladebehandling, så før møblet tages i brug anbefaler vi at man efterbehandler det med olie beregnet til møbler i træ. For yderligere info se vedligeholdelses guiden sidst i denne samvejledning.

PLEASE NOTE

Your new furniture has been pre-treated with oil, so we recommend giving the product additional treatment with oil intended for wooden furniture before use. For further information please see "maintenance guide" in this assembly instruction.

Kære kunde

Tillykke med dit nye køb.
Følg disse råd og få det bedste resultat, når du samler produktet.

- Læs vejledningen grundigt, før du går i gang
- Find hjælp, hvis I skal være to til at samle møblet
- Tjek at pakken indeholder alle dele på materialeoversigten
- Saml møblet på et blødt underlag, så du undgår ridser
- Følg vejledningen nøje
- Gem denne vejledning

Afsæt tid

Nogle møbler kan samles på få minutter. Andre – der f.eks. består af flere dele – kan tage over en time at samle. Afsæt god tid eller gør evt. arbejdet af flere omgange.

Mangler du enkeltdele, eller har du spørgsmål til samlevejledningen? Så kontakt kundeservice på ilva.dk

Venlig hilsen
ILVA

Dear Customer

Congratulations on your new purchase.
Follow this advice and get the best result when assembling the product.

- Read the instruction carefully before you start
- Get help, If two persons are required for assembly
- Make sure, you have all parts on the total material list
- Work on a soft, flat surface to avoid any damage to the finish
- Follow the assembly instruction
- Keep the assembly instruction

Allocate time

Some furniture can be assembled in minutes. Others – e.g. products in several parts – can take more than an hour to finish. Make sure to allocate good time or divide up the work.

If any parts are missing or if you have questions for the assembly instruction, please contact customer support at ilva.dk

Best regards,
ILVA

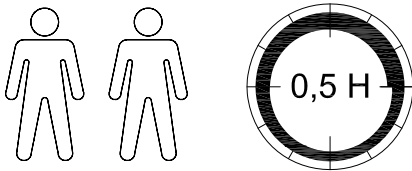

Tools needed

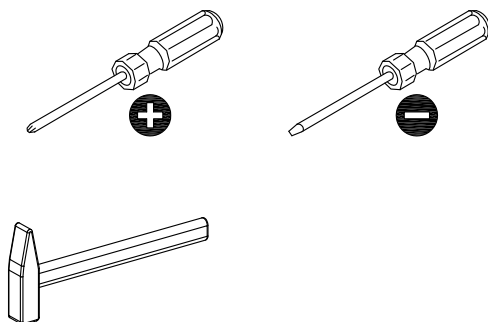

Don't use!!!

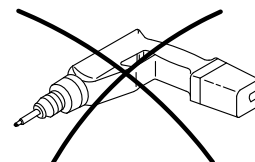

Total material list, hardware

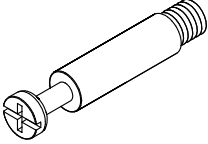
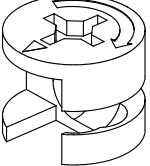
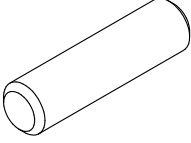
A x 8	B x 8	C x 8
 Ø6x41 mm	 Ø15 mm	 Ø7,8x30 mm

Total material list, furniture parts

			✓
①	1	1200x600x68	
②	2	1010x452x20	
③	1	935x400x45	

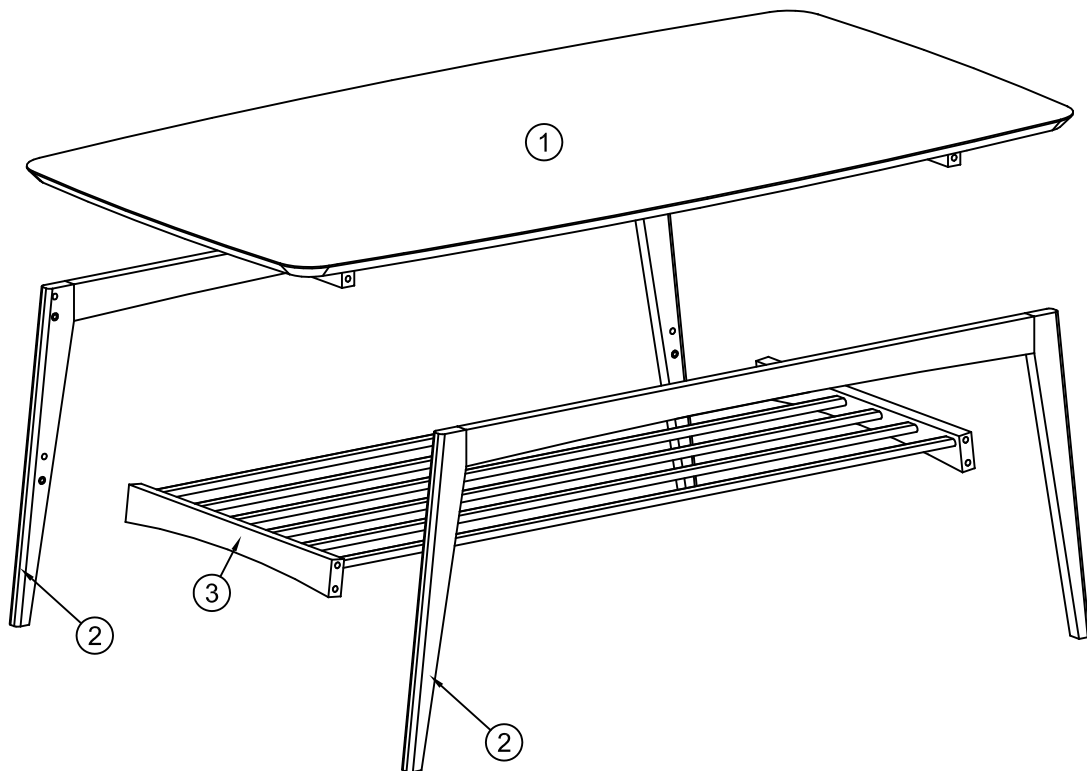

1

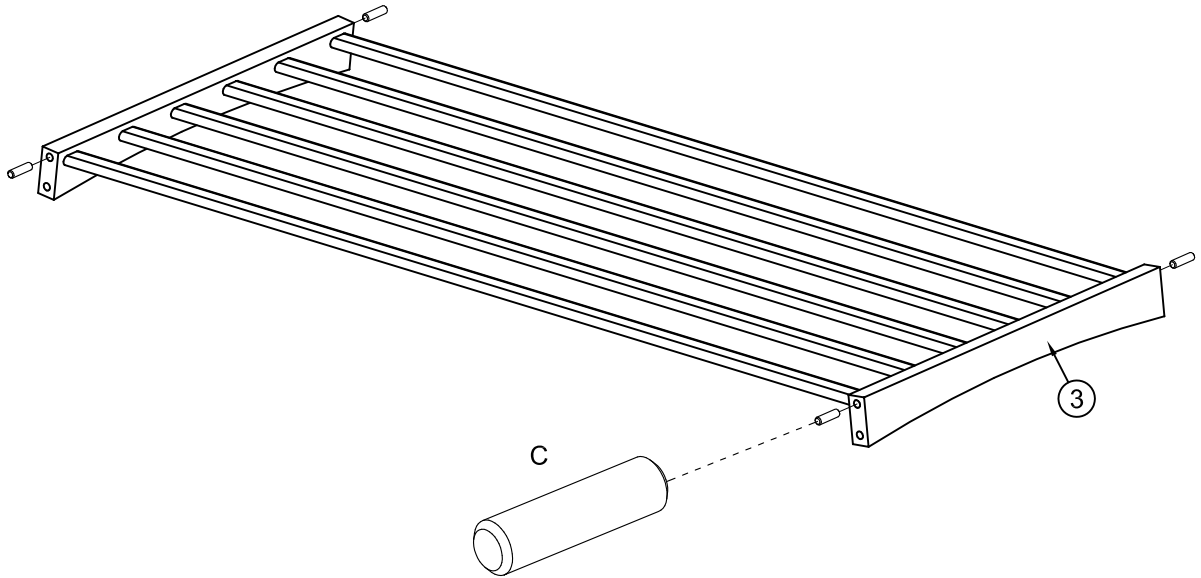
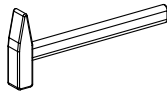
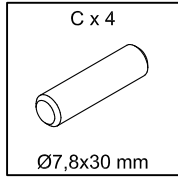

2

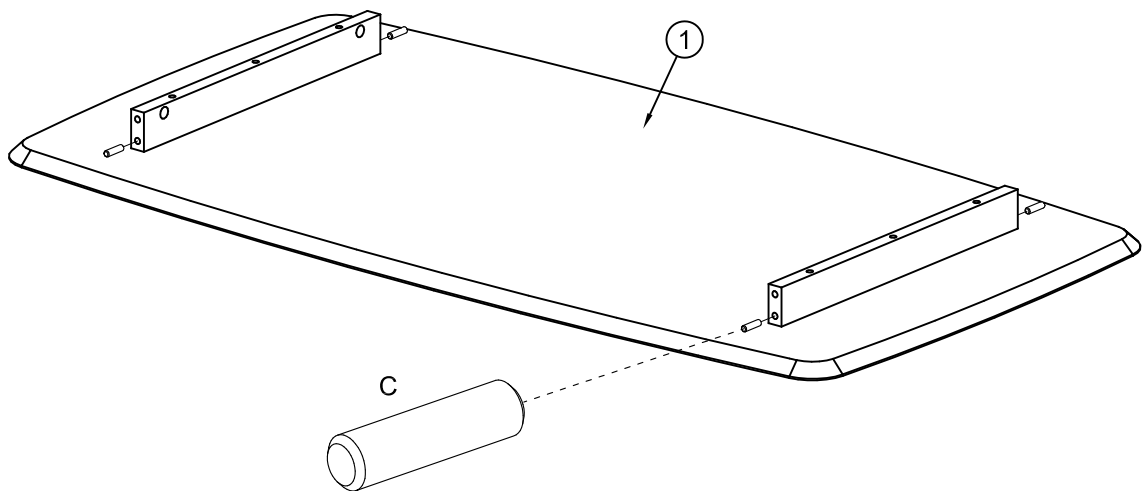
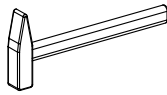
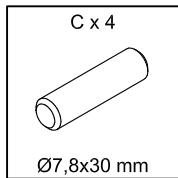

3

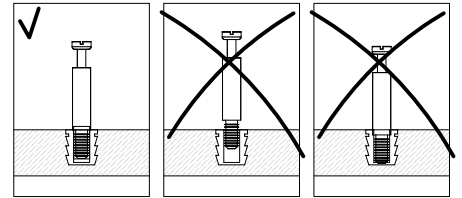
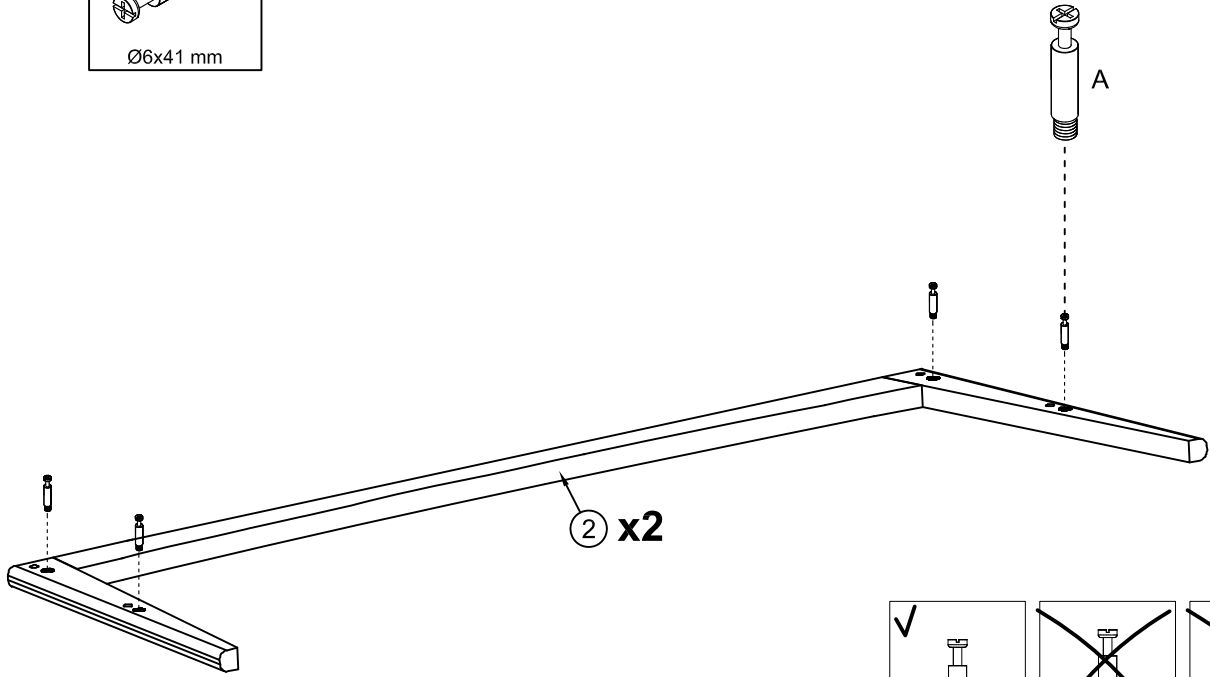
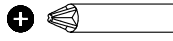
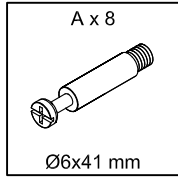

4

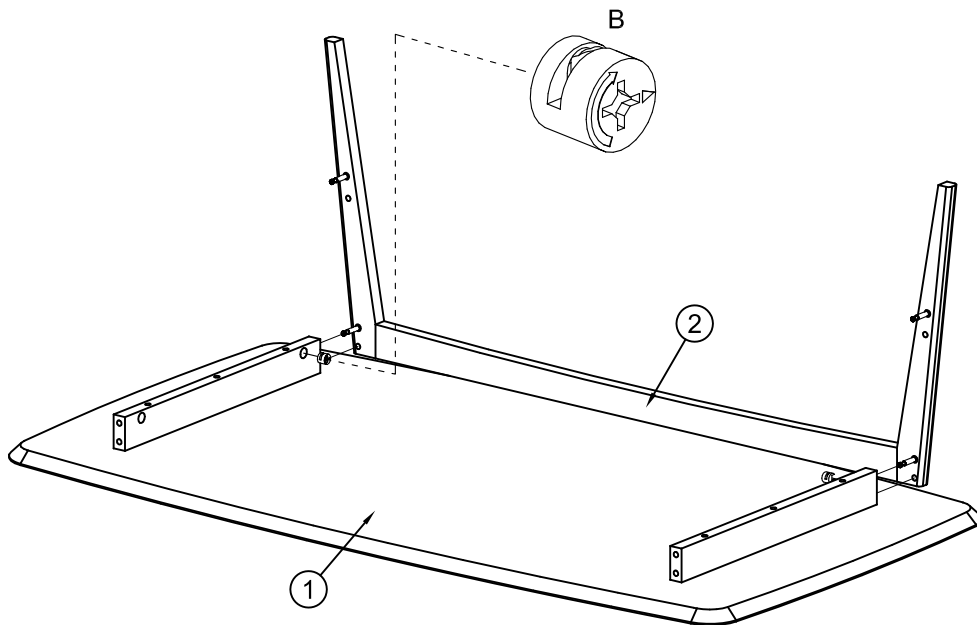
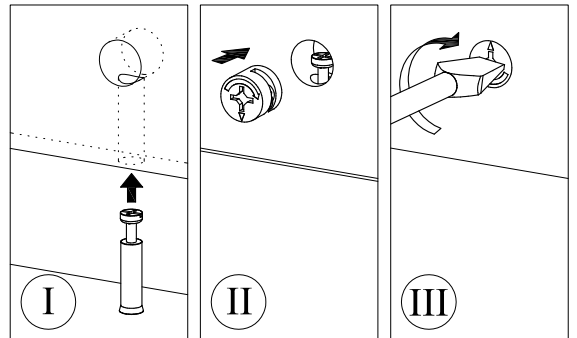
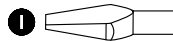
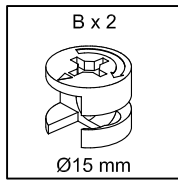

5

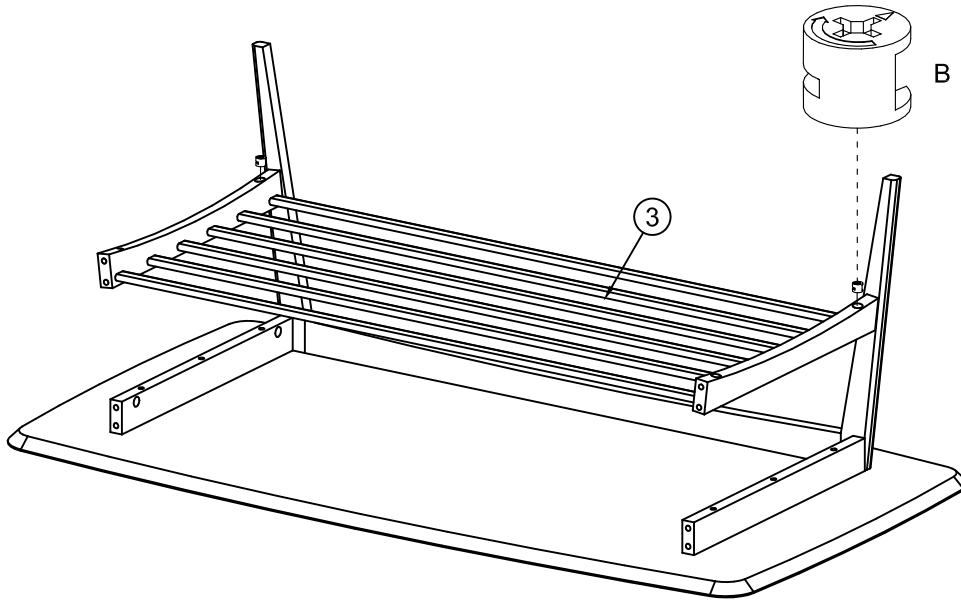
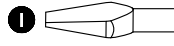
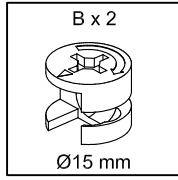

6

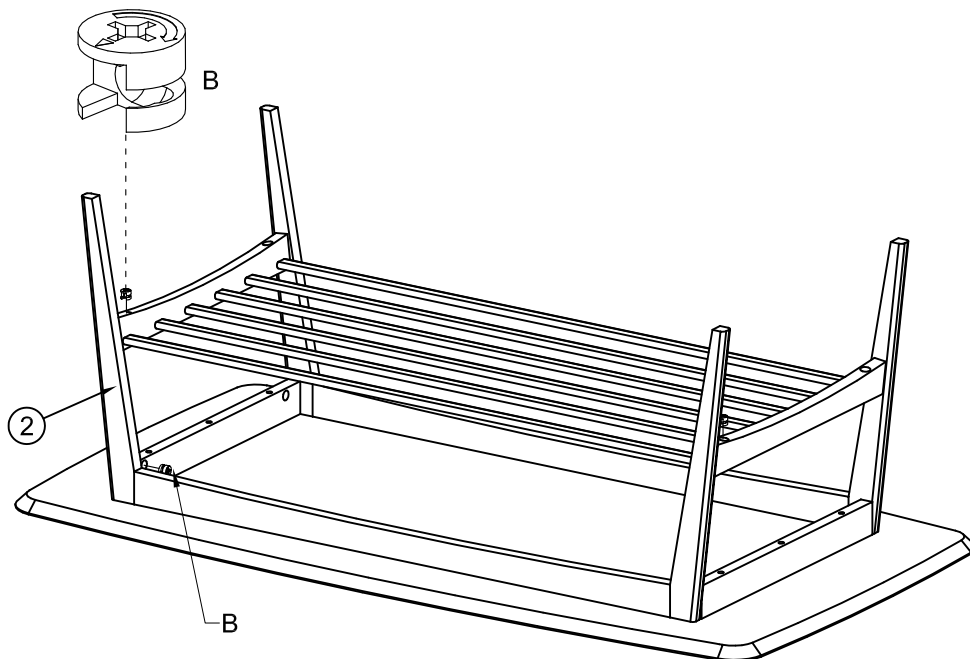
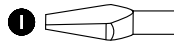
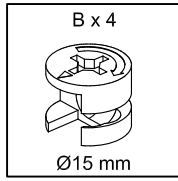

7

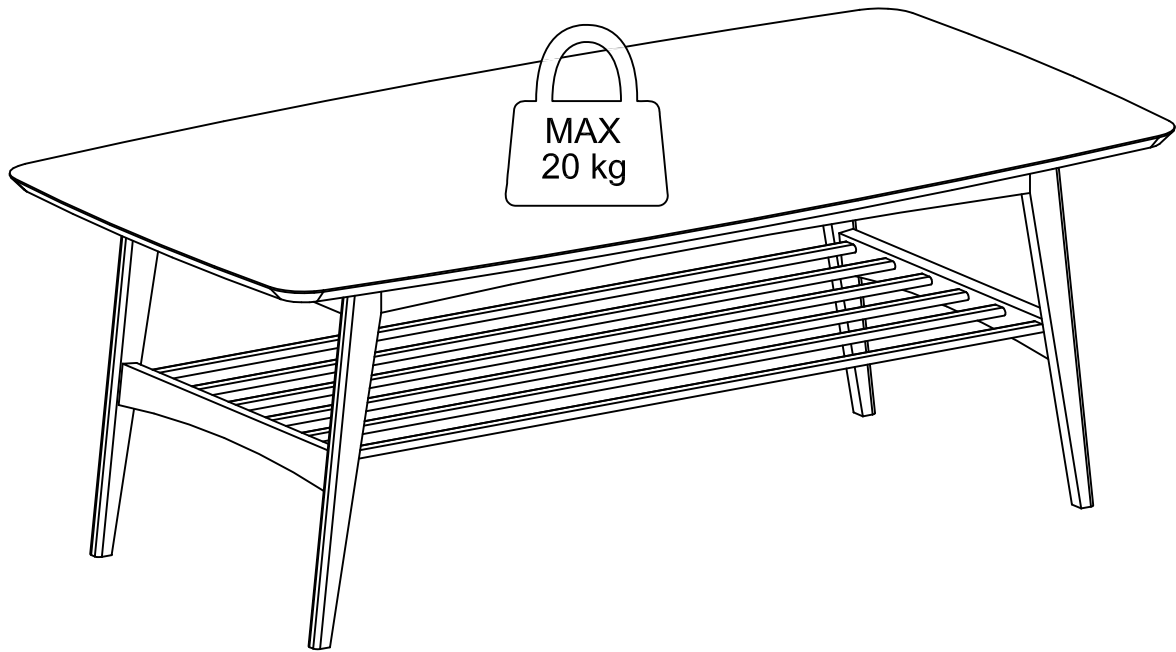

VIGTIGT!

Det er vigtigt, at alle produkter, der samles med alle former for skruer, efterspændes **en måned** efter samling samt hver **tredje måned** for at sikre, at produktet er stabilt i hele dets levetid.

IMPORTANT!

It is important that any product which is assembled using any kind of screw is re-tightened **one month** after assembly, and once every **3 months** - in order to assure stability through-out the lifespan of the product.

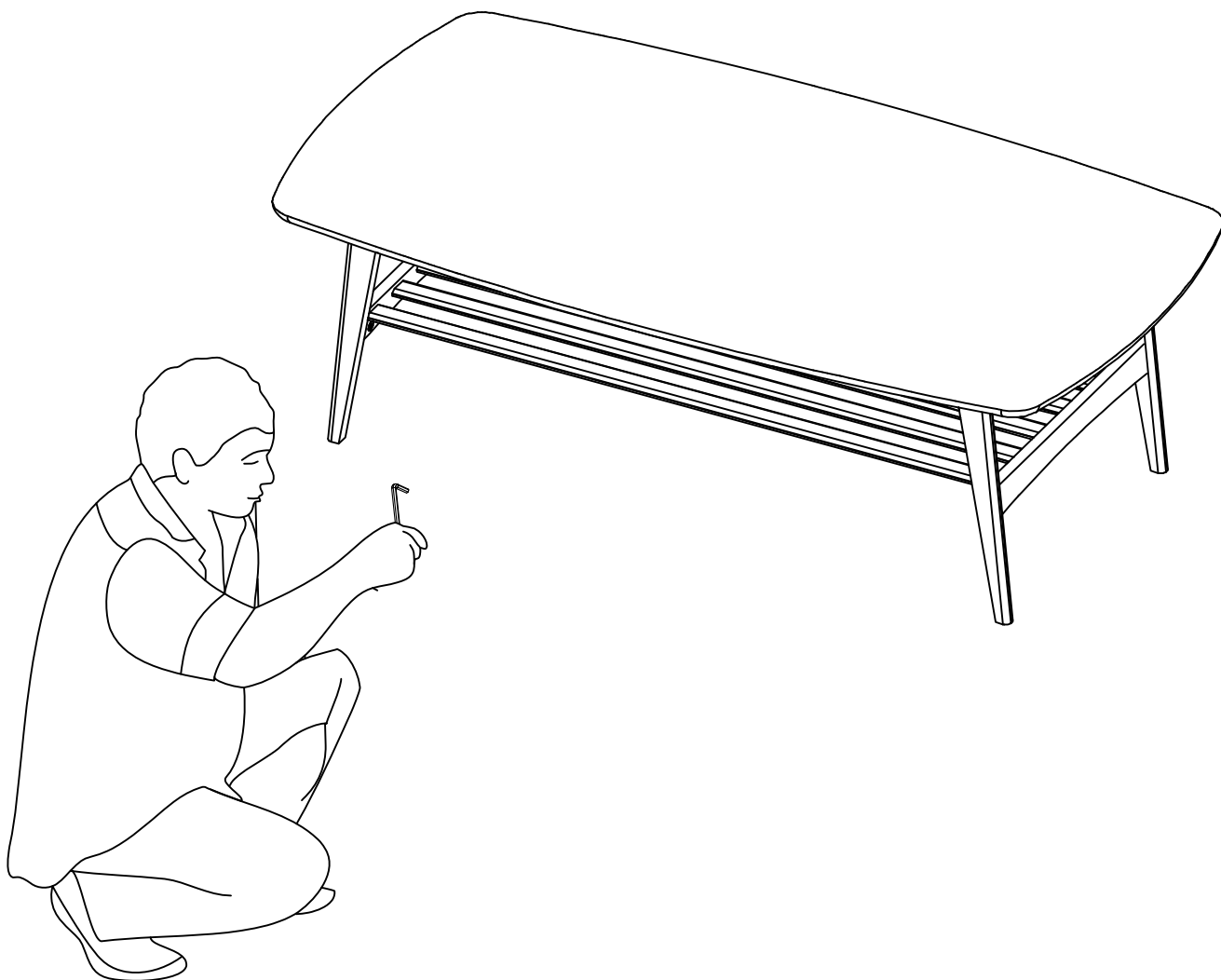
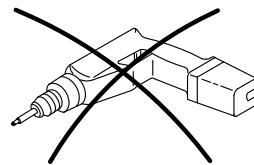

Vedligeholdelses guide

BEMÆRK: Dit nye møbel er leveret med en grund olie overfladebehandling, så før møblet tages i brug anbefaler vi at man efterbehandler det med olie beregnet til møbler i træ.

Træ er et naturmateriale og derfor findes der ikke to træmøbler som er helt ens - dette skyldes blandt andet åretegninger og knaster. Disse naturlige særpreg er ikke en fejl i træet, men blot en del af træets naturlige struktur.

MØBLET I HJEMMET

Efter fældning og opskæring af træet, "lever" træet stadig - hermed menes at træet stadig bliver påvirket af brug og omgivelser og små revner i træet kan opstå (også kaldet vindridser, disse er ubetydelige for produktets levetid). For at minimere ændringer på møblet, bør man være opmærksom på følgende:

- Farveændring kan ikke undgås ved normal brug, men du kan minimere ændringen ved at beskytte træet fra direkte sollys. Eksempelvis kan man med fordel vende møblet en gang imellem så farveændringen bliver ens over det hele.
- Indeklimaet har også en stor betydning. I de kolde og tørre vinter måneder trækker træet sig sammen, hvor træet i den fugtige og varme sommerperiode udvider sig. Sørg derfor for, at holde et stabilt indeklima på omkring 20 grader, en normal luftfugtighed på ca. 40-60 %, og undgå altid at have møblerne i uopvarmede rum.

MØBLER MED OMTANKE

Dit møbel har fra fabrikkens side fået en overfladebehandling, men derfor skal du stadig bruge det med omtanke. Spildes der på møblet, så bør pletten straks fjernes med en hårdt opvredet klud. Brug bordskåner eller glasbrikker, når noget stilles på møblet. Vær opmærksom på at møblet højst må være tildækket af plast eller voksduk i 12 timer af gangen, så man sikrer at træet kan ånde.

VEDLIGEHOLDELSE AF TRÆ

Der er forskel på hvordan forskellige træmøbler skal vedligeholdes, alt efter overflade og brug. Vi har herunder listet de mest almindelige overflader, og hvilken vedligeholdelse de kræver. Olierede og sæbebehandlede overflader kræver betydelig mere vedligeholdelse end lakerede møbler, og bør behandles ca. hver 4. måned eller efter behov. Ligeledes bør også nye møbler af disse typer behandles inde ibrugtagning. (Er man i tvivl, hvilken af nedenstående overflader ens møbel er produceret i, bør man altid kontakte sin møbel forhandler)

Oliebehandlede overflader / Hvidolierede overflader

Daglig rengøring - Hertil bruges en hårdt opvredet klud med en mild sæbeopløsning bestående af farve, PH- neutral sæbe og lukent vand. Møblet tørres nænsomt af med åreretningen.

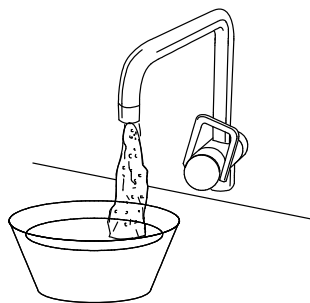

Maintenance guide

PLEASE NOTE: Your new furniture has been pre-treated with oil, so we recommend giving the product additional treatment with oil intended for wooden furniture before use.

Wood is a natural material, and no two wooden furniture is quite alike, this is partly due to veins and knots. This is part of the nature of the wood and are natural characteristics and thus not a fault in the wood.

FURNITURE IN YOUR HOME

After felling and cutting the wood is still "living", which means that use and surroundings will still influence the wood, and small cracks may appear (These are insignificant and have no influence on the lifespan of the product). In order to minimize changes in the furniture you should be aware of the following:

- Color variations cannot be avoided by normal use, but to minimize discoloration you must protect the wood from direct sunlight. For example, you could turn around the furniture, so the surface appears alike all over.
- The indoor climate has a vast influence. During the cold and dry winter months the wood will contract, whereas during humid and hot summer period it will expand. Try to keep a constant indoor climate around 20° C, and a normal air humidity of approx. 40-60%, and furthermore always avoid keeping the furniture in unheated rooms.

FURNITURE WITH CARE

Your new furniture has been pre-treated with oil from the factory, but still you need to use it with care. If any spills, please remove the stain immediately with a moist cloth. We strongly recommend use of place mats and coasters, whenever you place something on the furniture. All wooden surfaces may only be covered with an oil cloth for a maximum of 12 hours at a time, in order to allow the wood to breathe.

MAINTENANCE OF WOOD

Maintenance of various wooden furniture is different, depending on surface and use. Please find below a list of the most common surfaces, and how to maintain these. Oiled and whitewashed oil treated surfaces demand significantly more maintenance than lacquered furniture, and should be treated every 4th month, or as needed. Furthermore, we recommend giving the product an additional treatment before use. (If in doubt about the surface treatment of your furniture, please always contact your furniture retailer).

Oil treated surfaces/ whitewashed oil surfaces

Daily cleaning - Use a cloth firmly wrung in mild soapy water, consisting of colour, PH-neutral soap and lukewarm water. The furniture must be wiped off along the grains of the wood.

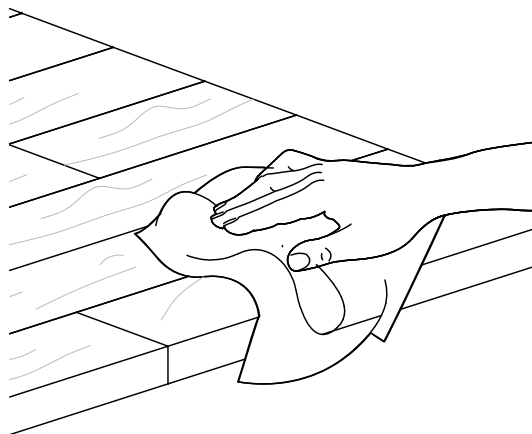

Vedligeholdelses guide

Vedligeholdelse - Start med at rengøre overfladerne som ovenfor og lad møblet tørre i et par timer.

Snarv som sidder fast i overfladen, og mindre ridser mv. kan med fordel fjernes/minimeres med en slibesvamp eller fint sandpapir korn 240. (Ståluld må ikke benyttes, da det kan misfarve træet).

Det er vigtigt at der altid slibes med åreretningen. Her er det vigtigt at være opmærksom på, om møblet er massivt eller i finer. På finerede møbler er trælaget typisk under 1 mm tyk, og kan derfor ikke slibes kraftigt, som man kan på massivt træ. Særligt på hjørner og tæt ved kanter, bør man være påpasselig, hvis der slibes på møblet.

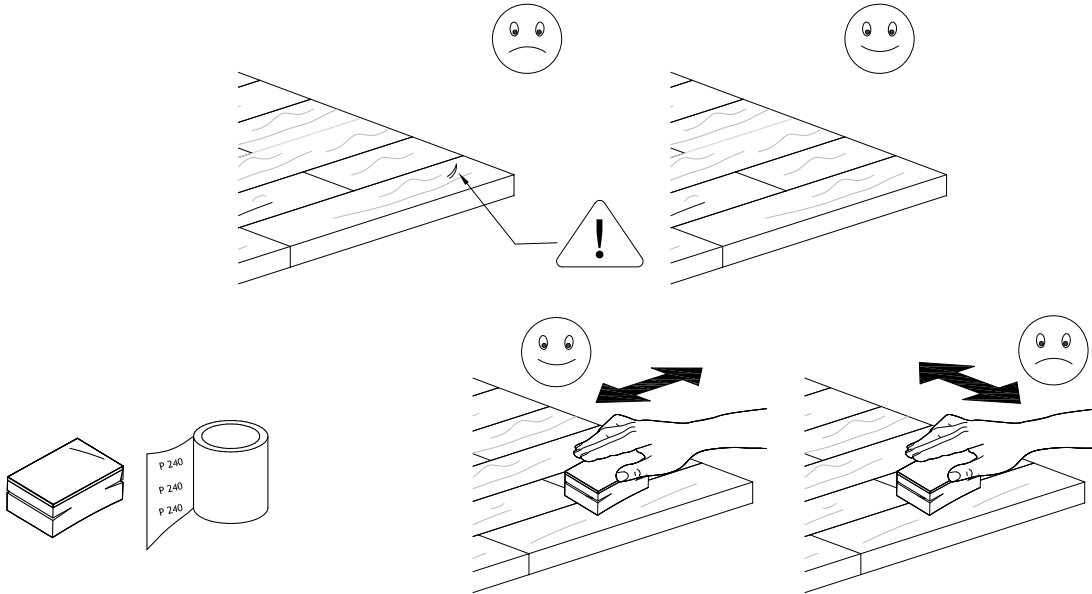

Når møblet er helt tørt, påføres olien. Dog vil der ofte være træfibre, som har rejst sig, så overfladen ikke føles glat. Dette er helt naturligt for træ, og fjernes nemt med nogle få strøg med en slibesvamp eller fint sandpapir korn 240. Ofte vil det også forekomme, når man aftørres møblet hvis ikke møblet er tilstrækkeligt mættet med olie. I så fald slibes igen som beskrevet ovenfor, og overfladen olieres igen.

Maintenance guide

Start with cleaning as per above, let the furniture dry for a couple of hours.

Any dirt stuck on the surface and any small cracks can be removed by sanding with sandpaper grain 240. (Do not use steel wool as this may discolour the wood)

It is important always to grind along the grains of the wood. It is also important to consider whether the furniture is solid wood or veneered. On veneered furniture the wooden layer is typically below 1 mm in thickness and cannot be as heavily grinded as on solid wood. You should also be aware of all corners and edges, if you will grind your furniture.

When the furniture is completely dry you can apply the oil. The surface of the product will often become rough after oil application, so the surface will not feel smooth. This is quite natural for wooden products and this roughness should be sanded down using sandpaper grain 240 along the grain direction. This will also happen if the furniture has not been adequately saturated with oil. If so, please repeat the treatment as described above, and reapply oil.

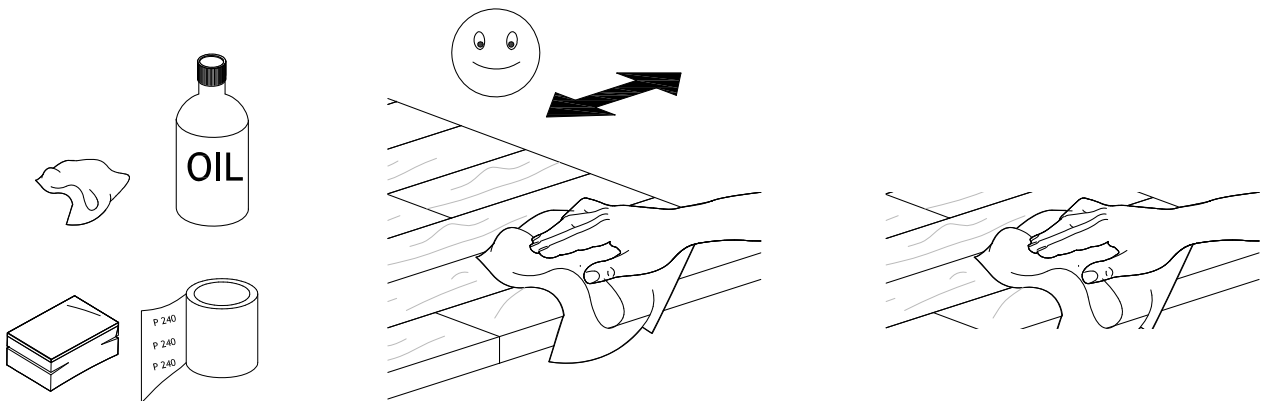

Det er vigtigt at være opmærksom på om møblet er behandlet med almindelig olie eller hvidolie. Vi anbefaler, at man genbehandler med samme type, for at opretholde den oprindelige farve bedst muligt. Man kan med fordel starte på bag-/ undersiden af eksempelvis bordplader. Dette vil gøre dig fortrolig med, hvordan opgaven udføres og samtidig sikre, at pladen ikke begynder at vride. Olien påføres med en neutral svamp eller klud, med åreretningen.

Med langt de fleste olietyper skal man efter påføring eftertørre, for at fjerne overskydende olie. Her anbefaler vi at man følger vejledningen på produktet. Særligt med hvidpigmenteret olie er det vigtigt, at olien påføres ensartet over hele møblet, da der ellers kan opstå hvide skjolder.

It is important to know whether the furniture is treated with bio oil or whitewash. We recommend you retreat with same type of oil as original, for the purpose of maintaining the original color as long as possible. It is preferable to begin by treating the back/underside of the furniture, for example on tabletops. This will make you comfortable with how the treatment is executed and ensure that the top does not start to warp. Apply the oil with a neutral sponge or cloth, along the grain direction.

With most oils it is necessary to wipe off the top after application, in order to remove excessive oil. We recommend that you follow the instructions on the product. Especially with whitewashed oil, it is important to apply an even layer on the furniture, given the risk of causing white stains.